

HV-D20P

**Color Camera
Specifications**

1. General

The HV-D20 is a three CCD color camera combining high picture quality and high stability with the convenience of C mount optics. CCD size is 1/2-inch and each is comprised of 470,000 picture elements. The circuits from processor to encoder are digitized and contained on a single LSI chip. Hitachi's extensive experience in broadcast and industrial color cameras has led to an exclusive 14-bit digital processing technology that provides a host of important functions in a newly developed LSI device. The high quality signal processing and image compensating functions were unattainable in earlier analog cameras. The versatile C mount also allows use with a broad range of optical systems and opens up applications in a wide variety of fields.

2. Features

1) Single chip LSI camera signal processor

Hitachi's leading edge processing technology (0.18 μ m, internal core 1.8V drive, and 3 million gates) is contained on a single newly developed ultra LSI chip. The system is compact and consumes very little power. Also, the 12-bit A/D converter and 14-bit internal processor provide high signal to noise ratio and wide dynamic range.

2) C mount

The camera uses a C mount lens, which is the de facto standard in the industry.

Note : Some lenses cannot be used. Check before use. See "9 when using lens".

3) High resolution

Three 1/2-inch 470,000 pixel CCDs with high sensitivity microlenses are mated to prism optics using high precision matching technology. Accelerated digital luminance signal processing is used to deliver a horizontal resolution of 800 TV lines (luminance channel).

4) High S/N

A new digital noise reduction system provides 62 dB signal to noise ratio. Clear low noise images are obtained even in high gain mode.

5) High sensitivity

The +24 dB high gain mode and +12 dB digital gain function combine for astonishingly high sensitivity. Minimum illumination is 0.4 lx and the noise reduction effectiveness allows scene pickup under adverse conditions beyond the capability of earlier CCD cameras.

- 6) Digital processing enables quality enhancement functions
 - Extensive experience in broadcast and industrial cameras is evidenced by the 6 vector independent variable masking, which is ideal for such applications as image processing and microscope technology where high color reproduction fidelity is essential.
 - Auto knee varies the high luminosity signal compression point according to the amount of incident light. Dynamic chroma compensates for color loss in high luminosity signals. Dynamic range is expanded to bring high reproduction quality even to outdoor scenes.
 - Variable detail boost frequency is also provided.

- 7) Auto shading compensation (ASC)

Color shading incurred when using a C mount lens is automatically compensated (attenuated). Two modes of shading are provided and can be selected according to the cameras application, a vertical color shading mode or a two-dimensional luminance-shading mode.

- 8) CCD drive functions
 - Preset electronic shutter mode (10 steps)
 - Lockscan mode reduces flicker in images with a different scanning frequency (e.g., a scene showing a computer display screen). The fixed frequency minimizes the appearance of a horizontal bar (not effective in all cases).
 - Auto electronic shutter (AES) maintains a fixed video level.
 - Long term integration mode accommodates field and frame integration (needs external video memory for a continuous picture).
 - Frame readout mode improves vertical resolution. (The sensitivity lower in AES mode of frame integration.)
 - Field on demand produces an image in response to an external trigger signal. (needs external video memory for a continuous picture).

- 9) Versatile pickup functions
 - Four scene files
Detail, masking, knee and other settings can be customized.
 - Real time automatic white balance adjustment. The variable detector gate function can be utilized to avoid white balance disruption even if a light source having a different color temperature enters the scene.
 - Intelligent ALC (auto level control)
The digital light meter and CPU processing provide continuous digital control of AGC, lens iris and auto electronic shutter over an extremely wide variation in lighting. The ALC level can be fine adjusted and the response selected for peak or average from the menu.
(Combining with AES is effective only with a manual override lens.)

- Full auto mode
- AGC and 1 step programmable gain switch
- Contrast function
- Flare compensation circuit
- Variable chroma level, Variable master black, R/B black, R/B gain
- Monochrome mode
- Color bar
- Title display
- Negative/positive selection
- Focus data output (Serial data output via RS-232C)

10) Bi-directional data transfer

A personal computer can be connected directly (RS-232C) for remotely controlling the camera functions. Conversely, the camera mode data are sent to the computer to allow very precise camera control. In multiple camera systems, each camera can be assigned an ID number to enable controlling multiple cameras from a single computer.

11) Switchable video signal outputs

The output can be selected for VBS, Y/C, RGB, Y/R-Y/B-Y according to the application.

3. Standard composition

3-1. Camera(HV-D20P)	1
3-2. Accessories		
1) Lens mount sheet	1
2) Power supply plug (R03-P3F)	1
3) Lens plug (E4-191J-100)	1
4) Operation manual	1

4. Specifications

1) Color system	PAL
2) Optical system	1/2-inch, F1.6 prism
3) Imaging system	R, G, B 3 CCD
4) Picture elements	Corresponding to 1/2-inch interline transfer CCD (with microlenses)
Total pixels	795 (H) × 596 (V)
Effective pixels	752 (H) × 582 (V)
Effective image area	6.35 (H) × 4.78(V) mm
5) Scanning system	2:1 interlace
6) Scanning frequency	15.634 kHz (H) × 50.00 Hz (V)
7) Encoder system	R-Y/B-Y
8) Sync system	Internal/external (VBS, BBS or HD/VD auto selection, when internal input/output switch is input position)
9) Horizontal resolution	800 TV lines, luminance signal center (Y out and DTL off)
10) S/N	62 dB type (DNR on), 59 dB type (DNR off) (Y out, $\gamma=1$, DTL off, GAIN 0 dB)
11) Standard sensitivity	2000 lx, F11
12) Minimum illumination	0.4 lx (50 IRE, F1.6, GAIN +24 dB, DIGITAL GAIN +12 dB)
13) Gamma correction	0.45/1.0 (on/off)
14) Geometric distortion	Full screen 0% (not including lens characteristics)
15) Registration	Full screen 0.05% (not including lens characteristics)
16) Vertical contour compensation	2H
17) Lens mount	C mount (flangeback 17.25 mm in air)
18) Sensitivity selection	AGC (0 to +24 dB) or GAIN (0 to +24 dB step 1dB or step 3 dB on remote control menu)
19) Detail control	DTL level and frequency
20) Scene files	4 Files
21) Digital gain	+6 dB, +12 dB sensitivity increase by digital signal processing

- 22) CCD drive functions
- | | |
|------------------------|--|
| Preset: | 1/60, 1/250, 1/500, 1/1000, 1/2000, 1/4000,
1/10,000 1/20,000 1/40,000 1/100,000second |
| Lockscan: | 1/50.31 to 1/2024 second (step 1H)
to 1/100,000 second (step approx. 10% video level) |
| AES: | Off to approx. 1/100,000 second |
| Long term integration: | Field/frame integration selectable |
| Field integration | 1/25 to approx. 4 seconds (1 frame steps) |
| Frame integration | 1/25 to approx. 8 seconds (1 frame steps)
(external image memory needed for continuous image) |
| Frame readout | improves vertical resolution
(residual image response deterioration) |
- 23) Color bar Full
- 24) Power supply voltage 12 V rated
(Stable operation at 10.5 to 15 VDC (ripple and noise absent))
- 25) Power consumption Approx. 5.0 W
- 26) Dimensions 65 (W) × 65 (H) × 130 (D) mm
- 27) Mass Approx. 450 g (not including lens)
- 28) Ambient temperature Operating -10 to 45 °C
Storage -20 to 60 °C

5. Input and output signals

5-1. Input signal conditions

1) Genlock input (MULTI connector)

- VBS 1.0 Vp-p ±3 dB or black burst/75 ohm or high (BNC)
(sync 0.3 ±0.1 Vp-p, burst 0.3 ±0.1 Vp-p)
- HD/VD 2 to 5 Vp-p, negative (D-sub connector)

Note: Genlock input and Sync output are selected by internal input/output switch.

2) External trigger input (MULTI connector)

Ext Trig Low 0 VDC, High 2 to 5 VDC

3) Serial data (REMOTE connector)

1.5 Vp-p ±3 dB/High (when connected to RC-Z3, JU-C20, JU-Z2)
RS-232C level (when connected to personal computer)

Note: Set internal switches according to connected equipment.)

A level converter JU-C20 is required if controlling the camera from a personal computer via RS-232C interface over a distance more than approx.15 meter.

5-2. Output signal ratings

- 1) Component video output (VIDEO, MULTI connector)

VBS 1.0 V_{p-p}/75 ohm

- 2) Y/C output (MULTI connector)

Y: 1.0 V_{p-p}/75 ohm

C: 0.3 V_{p-p} (burst)/75 ohm

- 3) Component output (MULTI connector)

Y : 1.0 V_{p-p}/75 ohm

R-Y: 0.7 V_{p-p}/75 ohm

B-Y: 0.7 V_{p-p}/75 ohm

- 4) RGB output (MULTI connector)

R: 0.7 V_{p-p}/75 ohm

G: 0.7 V_{p-p}/75 ohm

B: 0.7 V_{p-p}/75 ohm

Note: YC/VBS, component and RGB MULTI connector outputs are selected by menu.

- 5) Sync outputs (MULTI connector)

HD: 2 V_{p-p}/75 ohm

VD: 2 V_{p-p}/75 ohm

Sync: 2 V_{p-p}/75 ohm

Note: Genlock input and Sync outputs are selected by internal input/output switch.

- 6) Serial data output (REMOTE connector)

1.5 V_{p-p}/Low (when connected to RC-Z3, JU-C2-, JU-Z2)

RS-232C level (when connected to personal computer)

Note: Set internal switches according to connected equipment.)

- 7) Lens iris control (Lens connector, manual override)

IRIS CONT : 1.5 V (closed) to 5.5 V (open)

or 2.5 V (closed) to 7.5 V (open)

Selectable

6. External trigger signal timing

6-1. Pulse width control

1) Field on Demand (SHUTTER : EXT TRIG, EXT TRIG : MODE1, CCD MODE : FIELD)

The exposure time is controlled by external trigger pulse width. One field of the picture is obtained after SYNC reset. However, the exposure time must not be below 1/1,000s, even the minimum trigger pulse width.

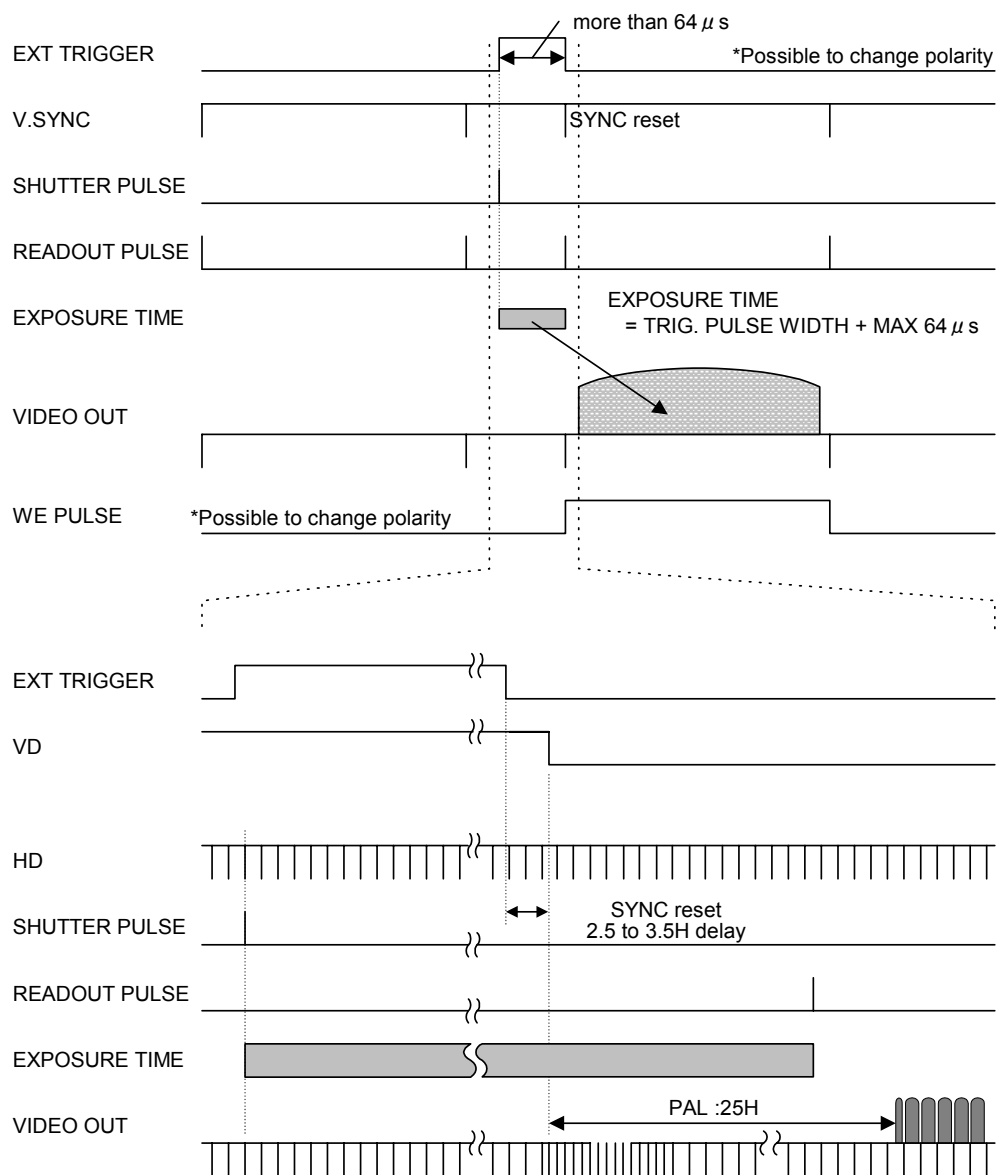

2) Frame on demand (SHUTTER : EXT TRIG, EXT TRIG : MODE1, CCD MODE : FRAME)

When an external flash trigger signal is applied, the V SYNC is reset and one frame of the picture is obtained. The exposure time is controlled by the external trigger pulse width and SYNC reset timing. Also, the SYNC reset timing from the flash timing can be adjusted by the camera menu setting.

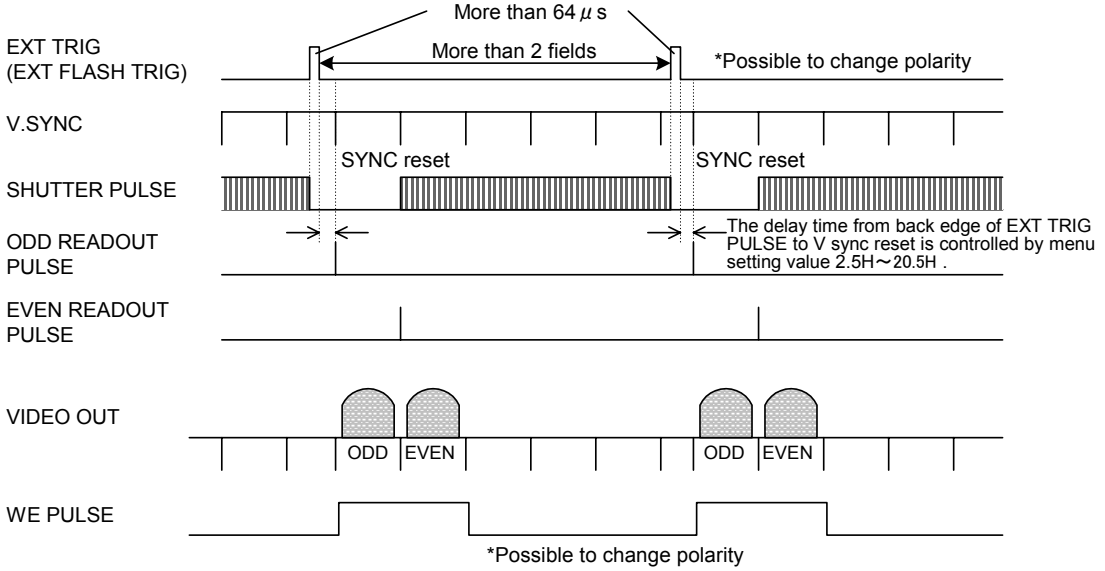

Note: When the flashlight is not used, the even and odd video signal levels are difference as shown to the following timing chart.

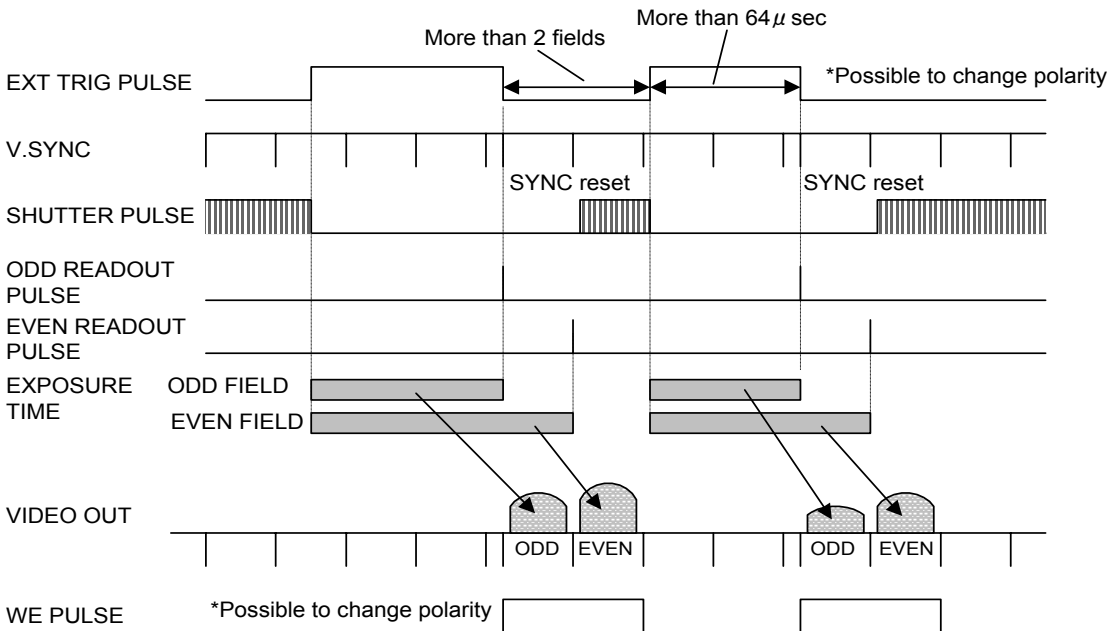

6-2. Long integration mode

(1) Field mode (SHUTTER : EXT TRIG, EXT TRIG : MODE2, CCD MODE : FIELD)

The trigger pulse width and the timing of external trigger pulse against the camera SYNC control the exposure time. One field of the picture is obtained at first ODD field after the back edge of external trigger pulse.

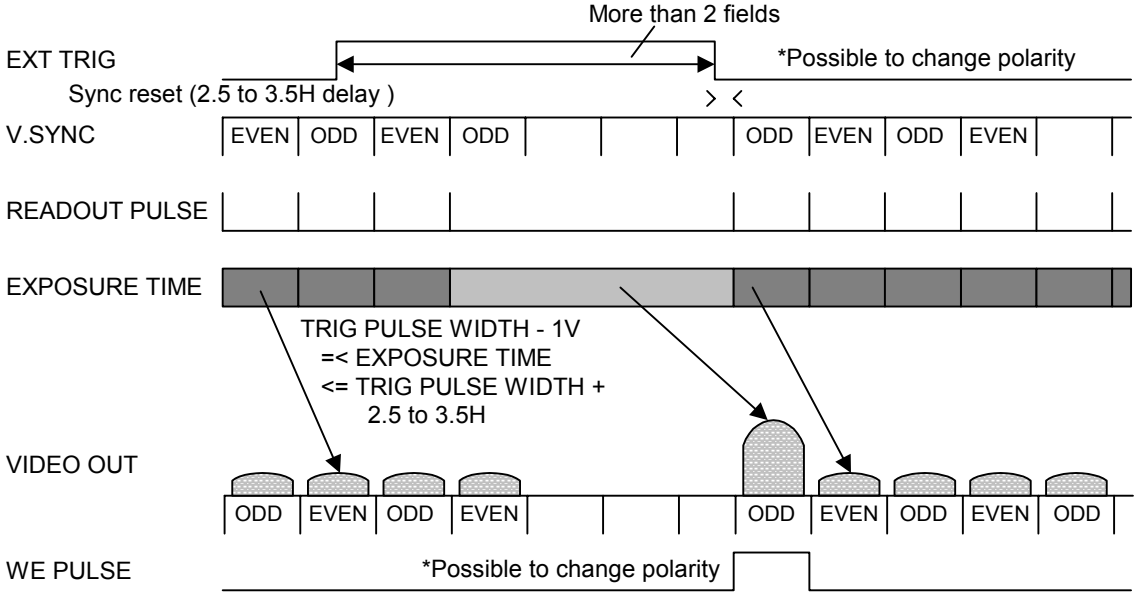

(2) Frame mode (SHUTTER : EXT TRIG, EXT TRIG : MODE1, CCD MODE : FRAME)

The trigger pulse width and the timing of external trigger pulse against the camera SYNC control the exposure time. One frame of the picture is obtained at first ODD field after the back edge of external trigger pulse.

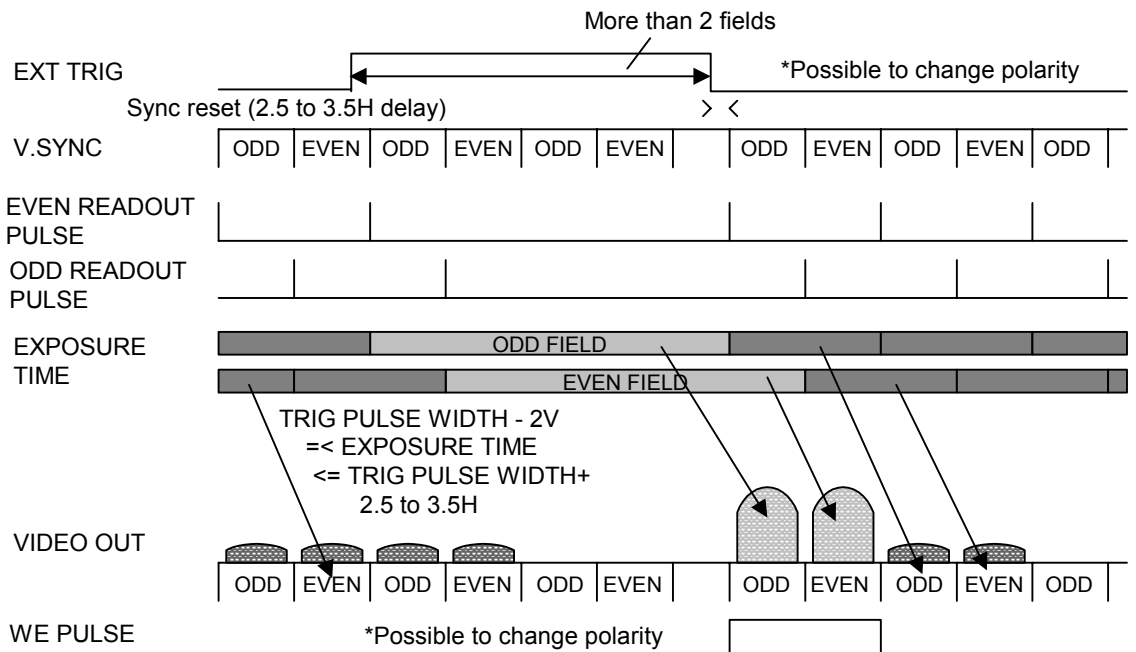

Note: For each external trigger mode, when the end edge of external trigger pulse is input in the timing period when it showed to the under figure, the picture is not output after the SYNC reset. Please input the repetition period of trigger pulse with the following specification, to avoid the trigger input to an above prohibition period.

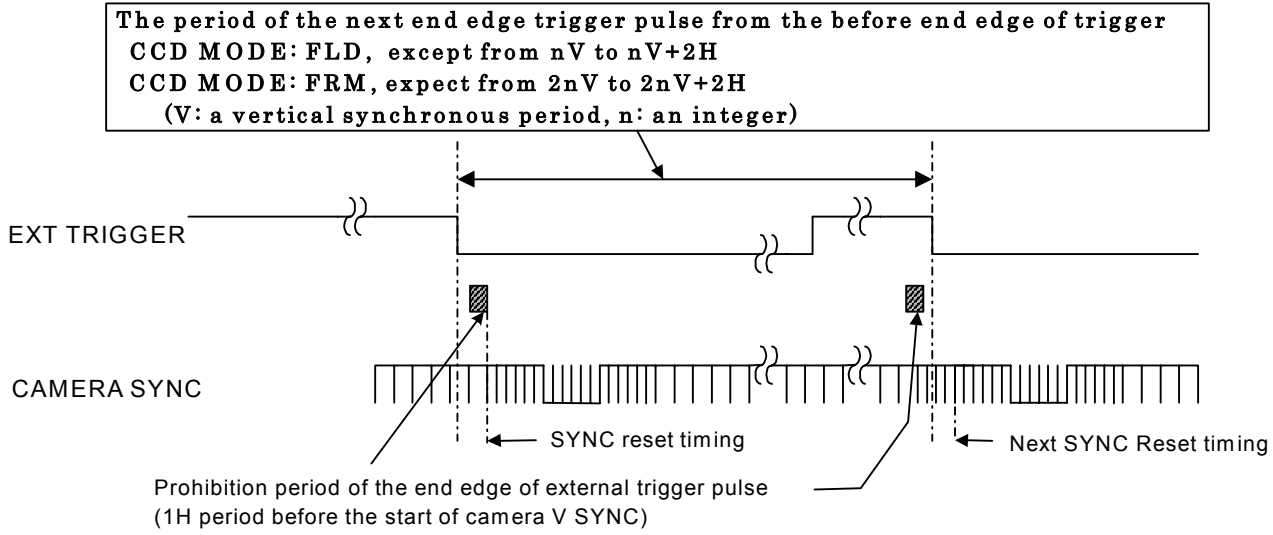

7. Connectors

1) MULTI connector (DMSH-15S)

Plug: Housing KEC-15P

Pin contact JK-SP2140

Cover JK-C151C

Screw No4-40UNC

Pin No	Signal name
1	R/R-Y/C OUT
2	G/Y/Y OUT
3	B/B-Y/VBS
4	WE OUT
5	GND
6	VIDEO GND
7	VIDEO GND
8	VIDEO GND
9	UNREG +12V IN
10	TRIG IN
11	GND
12	RXD
13	HD IN/HD OUT/ SYNC OUT
14	VD IN/GL IN/VD OUT
15	TXD

2) REMOTE connector (HR10A-7R-4S)

Plug: HR10A-7P-4P

Pin No	Signal name
1	UNREG +12V OUT
2	RXD/SD IN
3	TXD/SD OUT
4	GND

3) 12V IN connector (R03-R3M2)

Plug: R03-P3F

Pin No	Signal name
A	GND
B	UNREG +12V IN
C	NC

4) LENS connector (D4-151N-100)

Plug: E4-191J-100

Pin No	Signal name
1	+12V OUT
2	NC
3	IRIS CONT/VIDEO
4	GND

8. Major accessories

1) Camera control box

RC-Z3

2) RS-232C level converter

JU-C20, JU-Z2

9 when using lens

1) Projection (T) from flange face to rear of lens

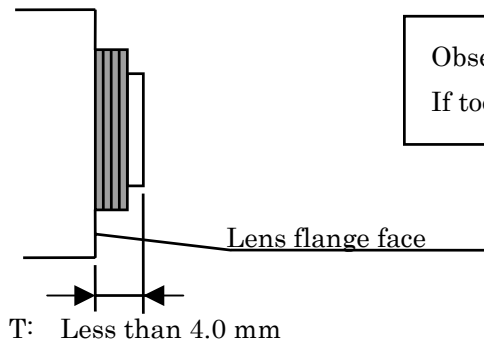

Observe the lens mount size limit indicated in the figure.
If too large, the lens and camera can be damaged

2) Selecting lens

Overall camera lens make performance is largely affected by the lens. It is recommended to check the following points beforehand.

- Ghosting can occur by using a lens with a large image area (e.g. 2/3 inch). Use a 1/2 inch lens.
- Vertical color shading can occur if the lens has a short exit pupil length.
- If the lens is used at nearly fully open iris, resolution is sacrificed, while such problems as shading and flare can detract from the image quality.

10. Exploded view

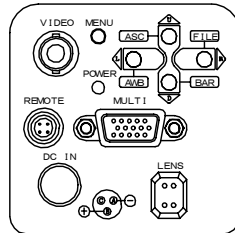
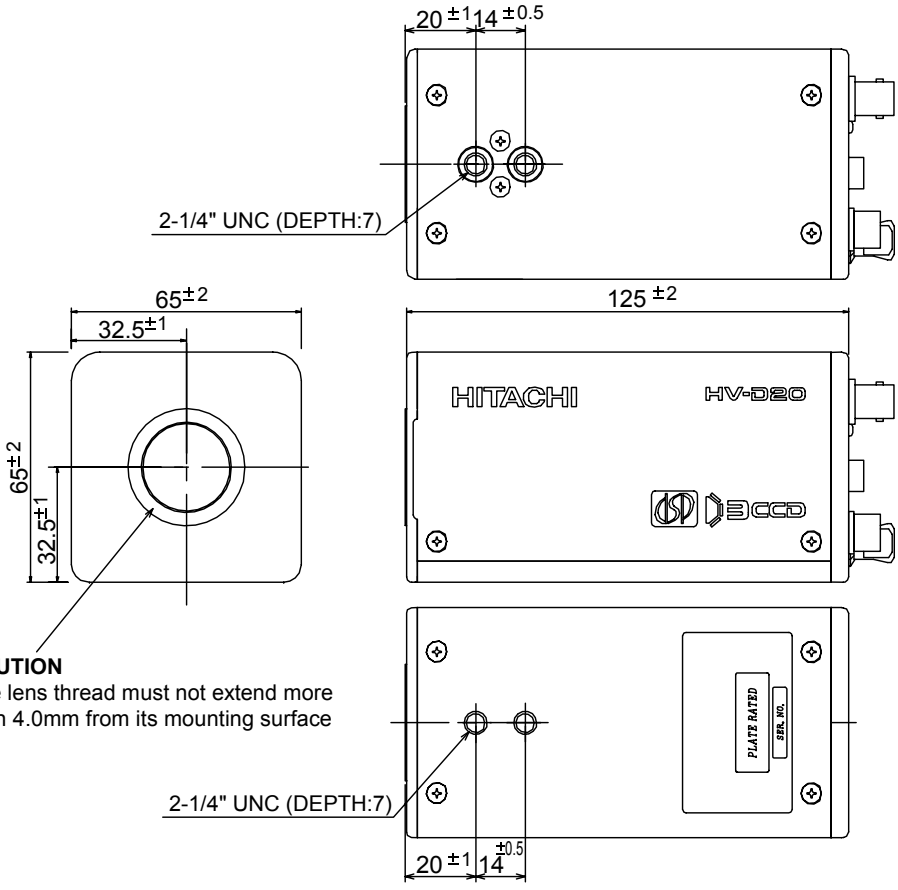

CAUTION
 The lens thread must not extend more than 4.0mm from its mounting surface

11. System example

